

ITA / ENG

ITA / ENG

ROBOPAC

MACHINERY

PRODUCTION PLANTS

ROBOPAC MACHINERY

Via Fabrizio da Montebello, 81 - 47892 Gualdicciole - Repubblica di San Marino
T. (+378) 0549 910511 - robopac@robopac.com
www.robopac.com

ROBOPAC SYSTEMS

S.P. Marecchia, 59 - 47826 Villa Verucchio, Rimini - Italy
T. (+39) 0541 673411 - robopacsystems@robopac.com
www.robopacsystems.com

ROBOPAC PACKERS

Via Ca' Bianca, 1260 - 40024 Castel San Pietro Terme, Bologna - Italy
T. (+39) 0541 673411 - robopacpackers@robopac.com

Via J. Barozzi, 8 - Z.I. Corallo - 40053 Valsamoggia, Bologna - Italy
T. (+39) 051 960302 - robopacpackers@robopac.com
www.robopacpackers.com

ROBOPAC BRASIL

Rua Agnese Morbini, 380 - 95700 - 404 Bairro Pomarosa
Bento Gonçalves / RS - Brazil
T. (+55) 54 3455-7200 - robopacbrasil@robopacbrasil.com
www.robopacbrasil.com

TOPTIER

10315 SE Jennifer St, Portland, Oregon 97015 - USA
T. (+1) 503 353 7588 - sales@toptier.com
www.toptier.com

SUBSIDIARES

ROBOPAC UK

Packaging Heights, Highfield Parc - Oakley - Bedford MK43 7TA - UK
T. +44 (0) 1234 825050 - sales@aetnagroup.co.uk
www.aetnagroup.co.uk

ROBOPAC FRANCE

4, Avenue de l'Europe - 69150 Décines - France
T. +33 (0) 4 72 14 54 00 - commercial@aetnafr.aetnagroup.com
www.aetnagroup.com/fr

ROBOPAC DEUTSCHLAND

Withauweg, 5 - D-70439 Stuttgart - Germany
T. (+49) 711 80 67 09 - 0 - info@aetna-deutschland.de
www.aetnagroup.com/de

ROBOPAC U.S.A.

2150 Boggs Road, Building 200, Suite 200 - Duluth, GA 30096 USA
T. (+1) 678 473 7896 - (+1) toll free 866 713 7286
info@aetnagroupusa.com
www.robopac.com/US

ROBOPAC RUSSIA

129329 Moscow - Otradnaya str. 2B - building 7 office 1 - Russia
T. (+7) 495 6443355 - info@aetnagroupvostok.ru
www.aetnagroup.com/ru

ROBOPAC CHINA

Building 2, No. 877, Jin Liu Road, Jinshan industry district, 201506, Shanghai - China
T. (+86) 0 21 62665966 - infochina@aetnagroup.com
www.aetnagroup.com.cn

ROBOPAC IBERICA

P.I. Portal Mediterráneo, Calle Dauradors 23 - 12500 - Vinaròs, Castellón - Spain
T. (+34) 964 860 901 - info@aetnaiberica.es
www.robopaciberica.es

Pluripac M

DISPOSITIVO PER CONFEZIONAMENTO A FREDDO
CON BOBINE DI FILM PLURIBALL, FOAM O POLIETILENE
BUBBLE WRAP, FOAM OR POLYETHYLENE REELS
COLD PACKAGING DEVICE



Rev. n. 00 - 3470300273 - 03/2019 - Acanto Comunicazione

Pluripac M

DISPOSITIVO PER CONFEZIONAMENTO A FREDDO CON BOBINE DI FILM PLURIBALL, FOAM O POLIETILENE
BUBBLE WRAP, FOAM OR POLYETHYLENE REELS COLD PACKAGING DEVICE



Compatibile con le avvolgitrici orizzontali manuali Compacta, nuove o già installate.
Compatible with manual horizontal wrapping machines Compacta, new or already installed.

LAYOUT COMPACTA + PLURIPAC M

	COMPACTA 6 + PLURIPAC M6	COMPACTA 9 + PLURIPAC M9
A	600 max	900 max
B	700 max	700 max
C	800 min / 900 max	800 min / 920 max
D	1880	2030
E	1544	1850
F	1438	1948
G	1100	1400
H	1575	2030
I	428	640
J	570	975
K	1046	1450
L	1120	1120
M	2210	2600
N	614	950
O	632	830

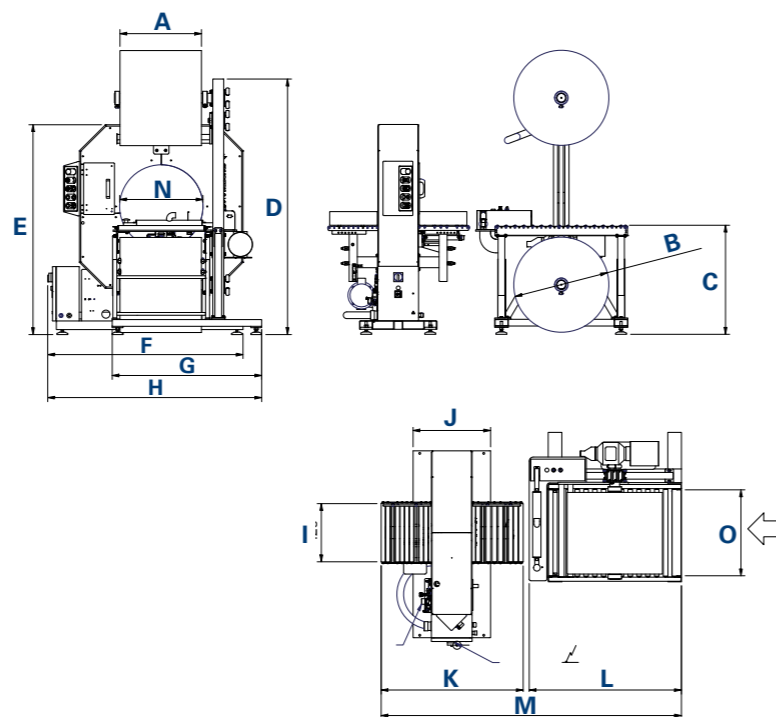

PERCHÈ PLURIPAC M? WHY PLURIPAC M?

- ▶ PROTEZIONE CONTRO GLI SHOCK AL PRODOTTO
PRODUCT SHOCK PROTECTION
- ▶ CHIUSURA TOTALE DEL PRODOTTO
TOTAL CLOSING OF THE PRODUCT
- ▶ BASSO CONSUMO ENERGETICO
LOW ENERGY CONSUMPTION
- ▶ SEMPLICITÀ DI ESECUZIONE
SIMPLICITY OF EXECUTION



DIMENSIONI PRODOTTO PRODUCT DIMENSIONS

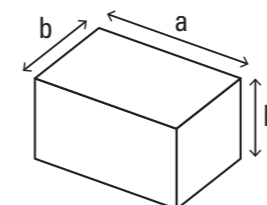

MACCHINA MACHINE	PLURIPAC M6		PLURIPAC M9		
	MIN	MAX	MIN	MAX	
lunghezza (a) length (a)	mm	100	∞	100	∞
larghezza (b) width (b)	mm	0	600	0	900
altezza (h) height (h)	mm	0	600	0	720

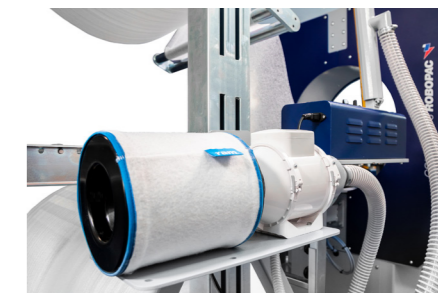
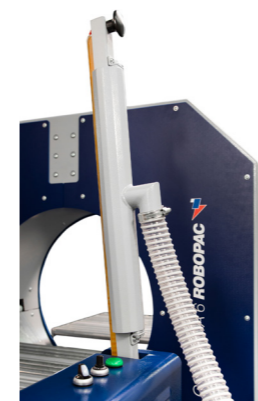

SALDATURA MANUALE AD IMPULSI / MANUAL IMPULSE WELDING

Saldatura manuale del film plastico sul prodotto e regolazione del tempo di saldatura. Sistema di aspirazione fumi mediante filtro.
Manual welding of the plastic film on the product and adjustment of the welding time. Fume extraction hood with filter.

CARATTERISTICHE TECNICHE TECHNICAL FEATURES

MACCHINA MACHINE		PLURIPAC M6	PLURIPAC M9
tensione di alimentazione power supply voltage	V	230 V 1 Ph	230 V 1 Ph
frequenza di alimentazione power supply frequency	Hz	50/60	50/60
potenza installata installed power	kW	1	1
corrente assorbita current consumption	A	8	8
diametro massimo bobina maximum reel diameter	mm	700	700
larghezza bobina reel width	mm	600	900
tipo film film type		pluriball, polietilene, poliolefine bubble wrap, polyethylene, polyolefins	pluriball, polietilene, poliolefine bubble wrap, polyethylene, polyolefins

I contenuti di questo catalogo sono stati verificati al momento della stampa. Robopac si riserva il diritto di modificare in ogni momento le caratteristiche tecniche dei prodotti e degli accessori illustrati nel presente documento. / The contents of this catalog have been verified before the press. Robopac reserves the right to modify in every moment the technical characteristics of the products and accessories illustrated in the present document.